



## Instruction Sheet: Fork Removal May2010.doc

Tools needed:

-5mm Allen Wrench

-1/2" Wrench

### Force R Fork components:

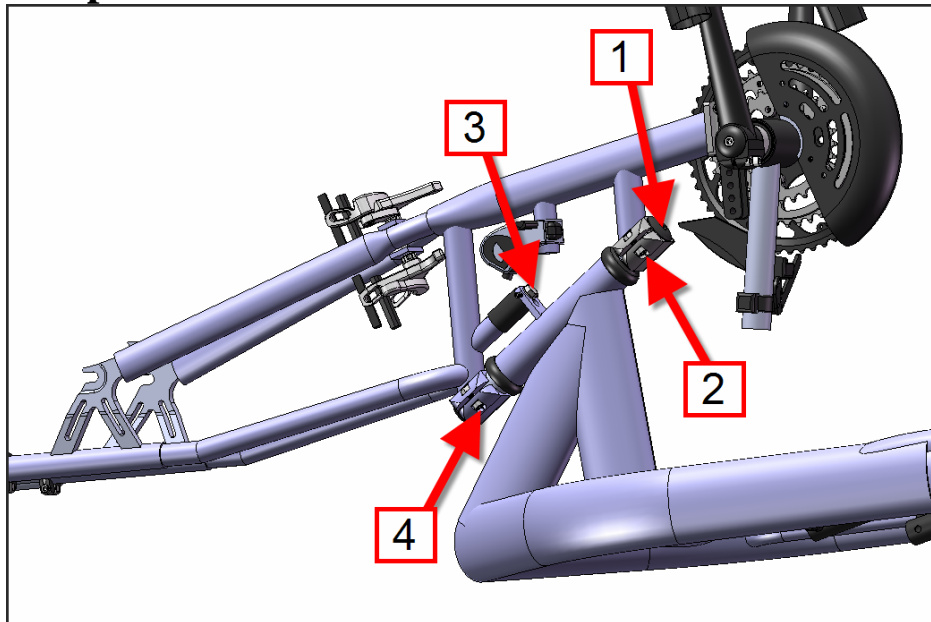

### REMOVAL STEPS:

1. Set front of Force R frame on something slightly off the ground.
2. Remove front wheel.
3. Using the 5mm allen wrench, loosen the Top Cap Bolt (1). *Do not remove.*
4. Using the 5mm allen wrench, loosen the Lower Fork Clamp Bolts (4). *Do not remove.*
5. Using the 1/2" wrench, loosen the Compensator Bolt (3). *Do not remove.*
6. Using the 5mm allen wrench, remove the Upper Fork Clamp (2).
7. Remove the Compensator Bolt (3).
8. Tip the Fork and slide off the end of the fork stem. Be sure not to lose top clamp or bolts.

### INSTALLATION STEPS:

1. Set front of Force R frame on something slightly off the ground.
2. Slide Lower Fork Clamp (4) over the fork stem. Push the fork so that Upper Fork Clamp (2) engages the upper portion of the fork stem.
3. Using the 5mm allen wrench, loosely attach Upper Fork Clamp / Bolts (2) with the lock-nuts facing upwards. *Do not fully tighten.*
4. Using the 5mm allen wrench, evenly and firmly tighten the Lower Fork Clamp Bolts (4)
5. Using the 5mm allen wrench, tighten the Top Cap Bolt (1) to remove play from the assembly.
6. Using the 5mm allen wrench, evenly and firmly tighten the Upper Fork Clamp (2)
7. Install and tighten the compensator bolt
8. Install front wheel.