

PER4MAX LYNX

Name: _____
 Address: _____
 City: _____
 State: _____ Zip _____

Date: _____ SO# : _____
 Age: _____ Weight (lbs.): _____
 Disability: _____
 Tel #: () _____ - _____

FRAME SPECIFICATION

Model

LYNX Retail: \$2295

1) Seat Width

12" 13" 14" 15" 16" 17" 18"

Optional Tapered @ the Knee _____" \$85

2) Seat Depth

12" 13" 14" 15" 16" 17" 18"

2a) Total Length _____"

3) Front Style (front end)

"Y" Std. Style \$N/C

"V" Style \$120

4) Rear Seat Height

14" 15" 16" 17" 18" Other _____"

Optional Plastic Seat Plate \$50

5) Front Seat Height

14" 15" 16" 17" 18" Other _____"

6) Backrest Height

10" 12" 14" 16" Other: _____"

Back Height Adj. : From _____" to _____" \$60

7) Back Angle

0° 3° 5° Other: _____° (⊥ Seat or ⊥ Floor)

8) Foot Width

7" 8" 9" 10" Other: _____"

9) Lower Leg Length _____" (16", 17", etc.)

10) Backrest To Center Axle

2" 3" 4" 5" Other: _____"

11) Center Axle To Caster Housing

15" 16" 17" 18" Other: _____"

12) Caster Housing To Front Foot Plate

1" 2" 3" 4" Other: _____"

13) Center of Caster to Caster

12" 14" 16" 18" Other: _____"

14) Side Wheel Clearance

1/2" 1" 1 1/2" 2"

15) Camber Angle

12° 15° 17° Other: _____°

Extra: _____° (Add \$195)

Notes:

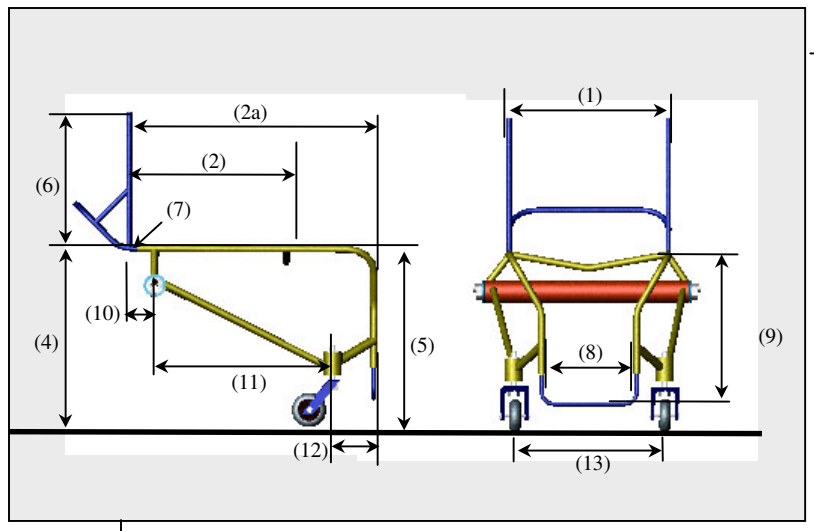

Effective: January 2004

Pricing and specifications are subject to change without notice

Customer Services: Telephone: 972-641-6773 Facsimile: 972-623-0585	PER4MAX MEDICAL www.per4max.com	2550 114th St. Ste. 190 Grand Prairie, TX 75050
--	---	--

PER4MAX LYNX

FRAME COLORS

- Sky White Bonded Silver Dormant Violet Ruby Red Glossy Black Safety Yellow
 Candy Blue Sparkle Green Safety Orange
 Other: _____ \$TBD
 Accessory Colors Standard Glossy Black Accessory Color Option _____ (one color additional: \$90)
 Backrest Footrest Removable 5th Wheel Side Guards

WHEELCHAIR OPTIONS

WINGS GUARDS

- NONE
 Wing guard \$N/C

5th WHEEL

- Rigid \$150
 Removable \$220

CLICK STRAP

- Waist Strap Size _____ " \$100
 Lap Strap Size _____ " \$75

BACK REST

- Rigid \$N/C
 Continues \$280

SIDE GUARDS (std. fixed)

- Aluminum \$140
 Plastic \$100
 Removable Extra \$75

CASTERS

- 3" (72mm) Micro \$N/C
 56mm Micro \$60
 Other _____ \$TBD

MISCELLANEOUS

- Spoke Guards \$100
 Foam Impact Guards \$60
 Extra Footrest \$90
 Special Upholstery \$180

WHEELS & TIRES

WHEELS

- Standard Wheels \$300
 24" 25" 26" 27"
 Spinergy Wheels \$695
 24" 25" 26" 27"
 Black White Blue Red Yellow

HAND RIM STYLE

- Hard Anodized 6 tab \$N/C
 Hard Anodized 12 tab \$75
 Vinyl Coated \$120
 Other _____ \$TBD

TIRES

- High Pressure Tires \$N/C
 Tufo High Press. Tires \$120
 Other _____ \$TBD

Notes:

Pricing and specifications are subject to change without notice

Customer Services:
 Telephone: 972-641-6773
 Facsimile: 972-623-0585

PER4MAX MEDICAL
www.per4max.com

2550 114th St. Ste. 190
 Grand Prairie, TX 75050