

# PER4MAX *PHOTON 4X*

Name: \_\_\_\_\_  
 Address: \_\_\_\_\_  
 City: \_\_\_\_\_  
 State: \_\_\_\_\_ Zip: \_\_\_\_\_  
 Email: \_\_\_\_\_

Date: \_\_\_\_\_ SSN# : \_\_\_\_\_ - \_\_\_\_\_ - \_\_\_\_\_  
 Age: \_\_\_\_\_ Weight (lbs.): \_\_\_\_\_ Height: \_\_\_\_\_' \_\_\_\_\_"  
 Disability: \_\_\_\_\_  
 Tel #: ( ) \_\_\_\_\_ - \_\_\_\_\_ (Home or Work)  
 Other Info: \_\_\_\_\_

## FRAME SPECIFICATION

### Model

**PHOTON 4X** ..... Retail: \$2195

1) Seat Width

12"  13"  14"  15"  16"  17"  18"

2) Seat Depth

12"  13"  14"  15"  16"  17"  18"

3) Top Total Length \_\_\_\_\_"

4) Rear Seat Height

14"  15"  16"  17"  18"  Other \_\_\_\_\_"

Optional Plastic Seat Plate ..... \$50

5) Front Seat Height

14"  15"  16"  17"  18"  Other \_\_\_\_\_"

6) Backrest Height

10"  12"  14"  16"  Other: \_\_\_\_\_"

Back Height Adj. : From \_\_\_\_\_" to \_\_\_\_\_" ..... \$60

7) Back Angle

0°  3°  5°  Other: \_\_\_\_\_° (⊥ Seat or ⊥ Floor)

8) Knee Width

8"  9"  10"  11"  Other: \_\_\_\_\_"

9) Lower Leg Length \_\_\_\_\_" (16", 17", etc.)

10) Backrest To Center Axle

2"  3"  4"  5"  Other: \_\_\_\_\_"

11) Backrest To Front Toe

11"  12"  13"  14"  Other: \_\_\_\_\_"

12) Center Axle To Caster Housing

18"  19"  20"  21"  Other: \_\_\_\_\_"

13) Side Wheel Clearance

1/2"  1"  1 1/2"  2"

14) Camber Angle

12°  15°  17°  Other: \_\_\_\_\_°

Extra: \_\_\_\_\_° (Add \$195)

## Notes:

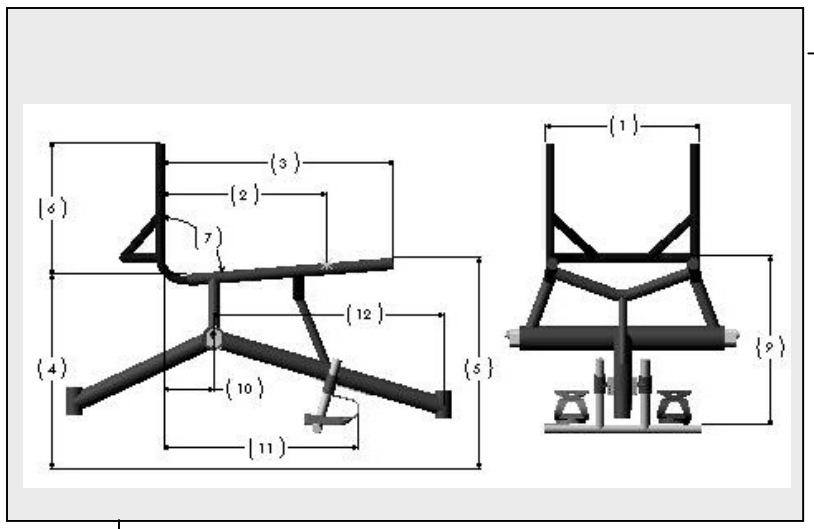

Effective: February 2005

Pricing and specifications are subject to change without notice

<p>Customer Services:                  Telephone: 972-641-6773                  Facsimile: 972-623-0585</p>	<p><b>PER4MAX MEDICAL</b>                  www.per4max.com</p>	<p>2550 114th St. Ste. 190                  Grand Prairie, TX 75050</p>
---	--	---

# PER4MAX *PHOTON 4X*

## FRAME COLORS

- Sky White     Bonded Silver     Dormant Violet     Ruby Red     Glossy Black     Safety Yellow  
 Candy Blue     Sparkle Green     Safety Orange  
 Other: \_\_\_\_\_ \$TBD  
 Accessory Colors Standard Glossy Black     Accessory Color Option \_\_\_\_\_ (one color additional: \$90)  
 Backrest     Footrest     Removable 5th Wheel     Side Guards

## WHEELCHAIR OPTIONS

### 5th WHEEL

- Rigid ..... NC  
 Removable ..... \$220

### CLICK STRAP

- Waist Strap Size \_\_\_\_\_" ..... \$100  
 Lap Strap Size \_\_\_\_\_" ..... \$75

### BACK REST

- Rigid ..... NC  
 Continues ..... \$280

### SIDE GUARDS (std. fixed)

- Aluminum ..... \$140  
 Plastic ..... \$100  
      Removable Extra ..... \$75

### CASTERS

- 3" (72mm) Micro ..... NC  
 56mm Micro ..... \$60  
 Other ..... \$TBD

### MISCELLANEOUS

- Spoke Guards ..... \$100  
 Special Upholstery ..... \$180

## WHEELS & TIRES

### WHEELS

- Standard Wheels ..... NC  
      24"     25"     26"     27"  
 Spinergy Wheels ..... \$695  
      24"     25"     26"     27"  
      Black     White     Blue     Red     Yellow

### HAND RIM STYLE

- Hard Anodized 6 tab ..... NC  
 Hard Anodized 12 tab..... \$75  
 Rhino Coated ..... \$120  
 Other ..... \$TBD

### TIRES

- High Pressure Tires ..... NC  
 Tufo High Press. Tires ..... \$120  
 Other ..... \$TBD

Notes:

Effective: February 2005

Pricing and specifications are subject to change without notice

Customer Services: Telephone: 972-641-6773 Facsimile: 972-623-0585	<b>PER4MAX MEDICAL</b> <i>www.per4max.com</i>	2550 114th St. Ste. 190 Grand Prairie, TX 75050
--	--	--